

D Vor dem Aufbau Anleitung lesen und für spätere Verwendung aufbewahren.

GB Before assembly, please read the instructions and then keep them for further reference.

F Avant le montage, lire la présente notice et la ranger afin de pouvoir l'utiliser à un moment ultérieur.

I Prima del montaggio, leggere le istruzioni e conservarle per un utilizzo successivo.

A		10 x	25101
B		10 x	25098
C/D		2 x	25401
E		8 x	25306
F		8 x	22271
G		8 x	22270
H		4 x	36680
		4 x	36682
I		8 x	25106
J		2 x	25303
K		3 x	
L		22 x	20305
M		1 x	29576
N		8 x	22802
O		4 x	25331
P		2 x	26110

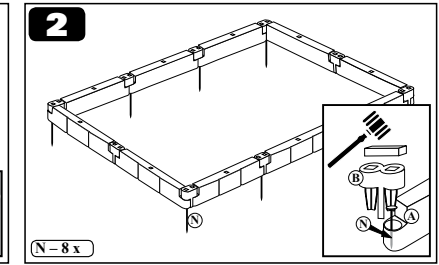
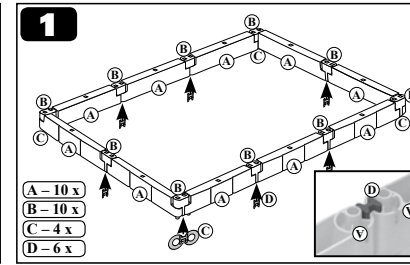
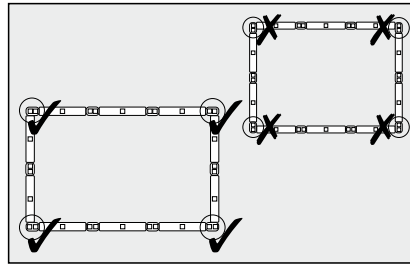
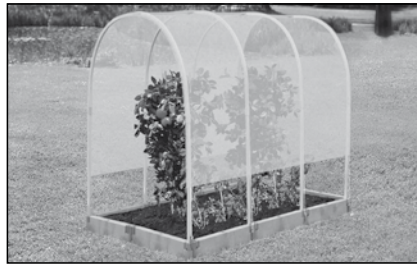

### Tomaten-Schutzhaus / tomato cloche / basse modulaire :

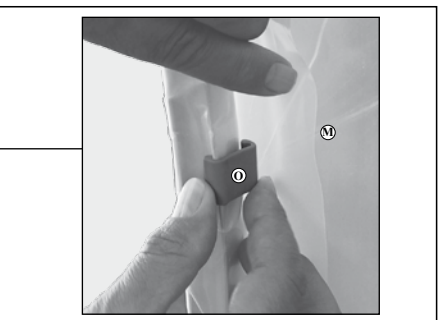
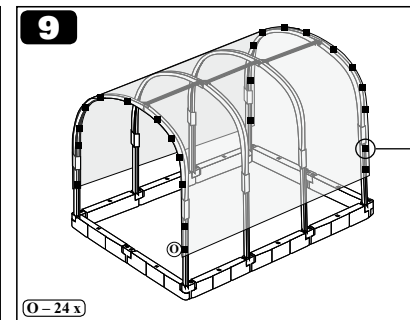
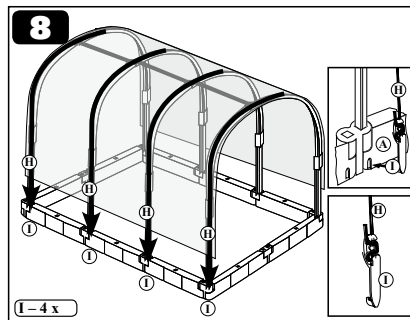
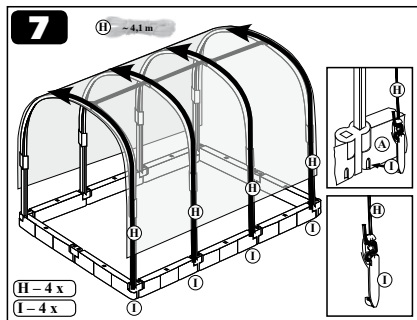
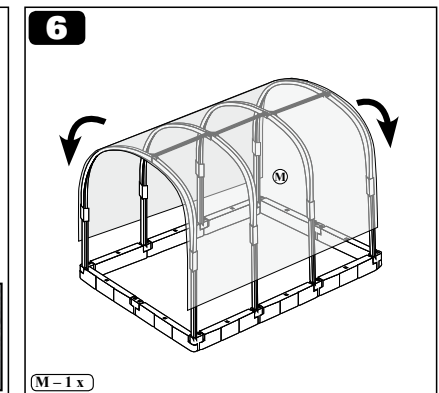
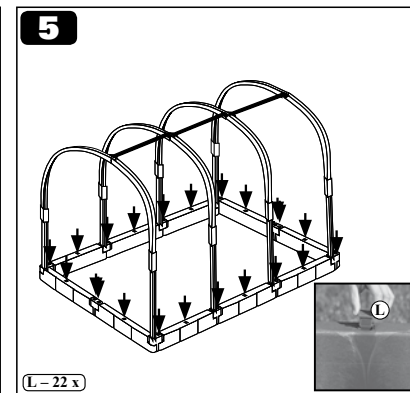
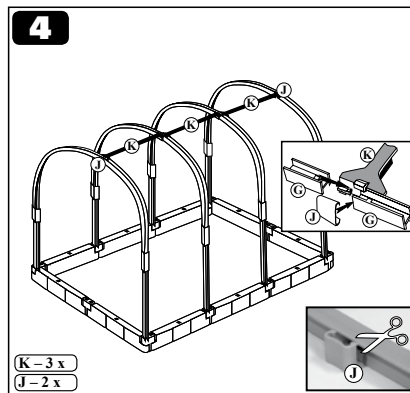
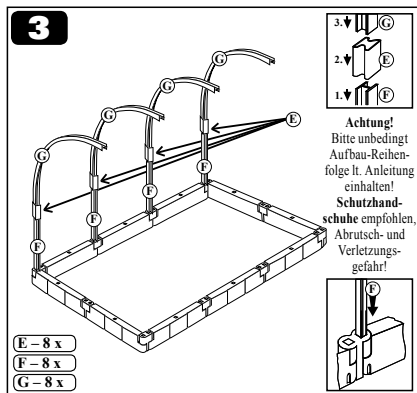

JUWEL H. Wüster GmbH  
D-82467 Garmisch-Partenkirchen, Bahnhofstraße 31 oder A-6460 Imst, Industriezone 19  
www.juwel.com · kund@juwel.com

**D** – Bitte vorerst am gewünschten Aufstellungsort Ihres Tomaten-Schutzhauses/Frühbeets für ebenen Untergrund sorgen.

**WARNUNG:** Ein vom Wind weggerissenes Tomaten-Schutzhaus kann Schaden verursachen. An Orten mit besonders starkem Windeinfluss kann eine zusätzliche Bodenverankerung erforderlich werden! Das Tomaten-Schutzhaus/Frühbeet ist nicht für Schneelast ausgelegt. Bitte bei Schneefall regelmäßig abräumen.

**Pflegehinweise:** Ihr JUWEL Qualitätsprodukt ist aus witterungsbeständigen Materialien gefertigt und kann ohne weiteres mit einem Gartenschlauch abgespritzt werden. Nicht mit scharfen, rauen Gegenständen oder aggressiven Reinigungsmitteln reinigen.

**GB** – First make sure that the ground where you wish to set up your raised bed is even.

**WARNING:** A tomato cloche torn away by the wind may cause damage. Additional ground anchoring may be required in places exposed to particularly strong winds. The tomato cloche is not designed for snowloads. In case of snowfall please clear away from snow regularly.

**Care instructions:** This JUWEL quality product was produced with weatherproof materials and may be washed down with a garden hose. Do not clean with sharp or rough objects or with aggressive detergents.

**F** – Veuillez en premier lieu vous assurer que le lieu de positionnement de votre plate-bande surélevée se trouve sur une surface plane.

**AVERTISSEMENT :** Une serre pour plantes grimpantes emportée par le vent peut causer des dommages. Dans des endroits particulièrement exposés au vent, un ancrage au sol supplémentaire peut s'avérer nécessaire. La serre pour plantes grimpantes n'est pas adaptée à supporter des poids (tels que neige ou glace). Prière

**D** Vor dem Aufbau Anleitung lesen und für spätere Verwendung aufbewahren.

**GB** Before erecting, please read the instructions and then keep them for further reference.

**F** Avant le montage, lire la présente notice et la ranger afin de pouvoir l'utiliser à un moment ultérieur.

**I** Prima del montaggio, leggere le istruzioni e conservarle per un utilizzo successivo.

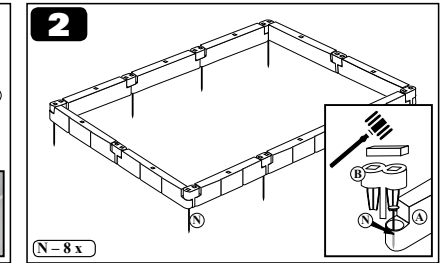
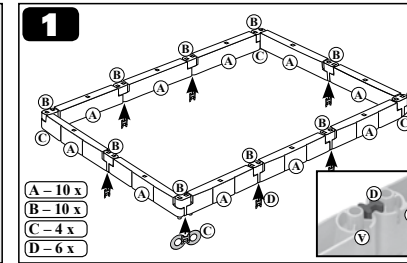
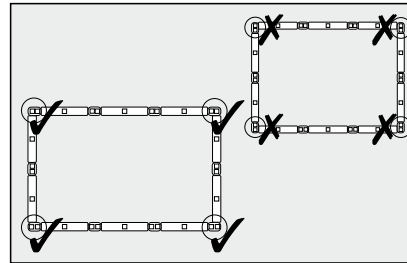

### oder Frühbeet / or cold frame / ou serre :

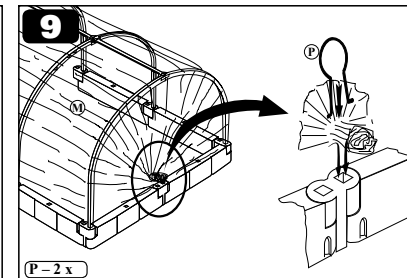
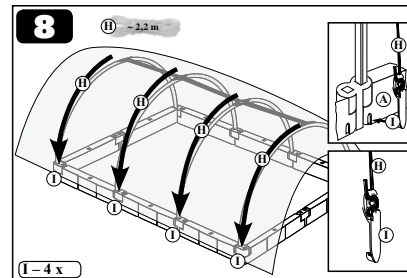
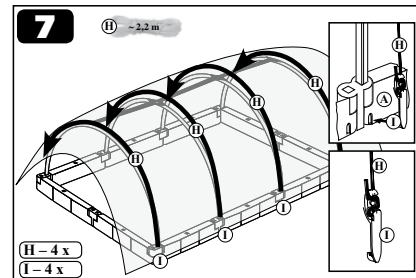
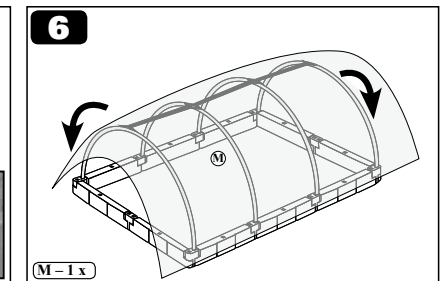
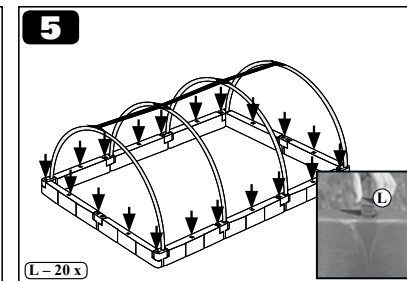
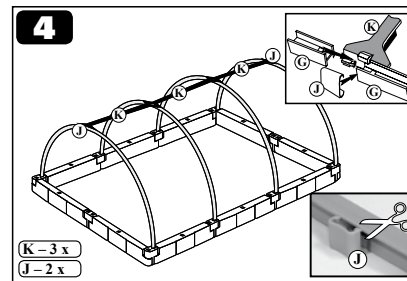
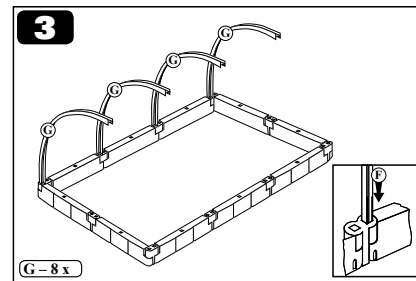

d'enlever la neige de la bâche en hiver.  
**Remarques concernant l'entretien :** ce produit de qualité JUWEL a été fabriqué à partir de matériaux résistants aux intempéries et peut être aspergé au jet d'eau sans problème avec un tuyau de jardin. Ne pas nettoyer avec des objets affûtés ou rugueux, ni avec des détergents agressifs.

**I** – Per prima cosa raccomandiamo di accertarsi che il luogo di installazione presenti fondo planare.  
**AVVERTENZA:** una serra da pomodori lacerata dal vento può provaocare danni. In luoghi particolarmente soggetti al vento, può risultare necessario un ancoraggio di fondo supplementare! La serra non è

dimensionata per carichi di neve. In caso di nevicate, procedere ad uno sgombero regolare.  
**Note di preservazione:** questo prodotto Juwel di qualità è realizzato in materiali resistenti agli agenti atmosferici e può essere senz'altro irrorato con un tubo flessibile di irrigazione. Non pulire con oggetti

acuminati o scabri oppure con detergenti aggressivi.